

Tied Clutch Brace

STM Screw-On, HD & Standard 30-33mm and Ski-Doo Primary

Part# 1001492

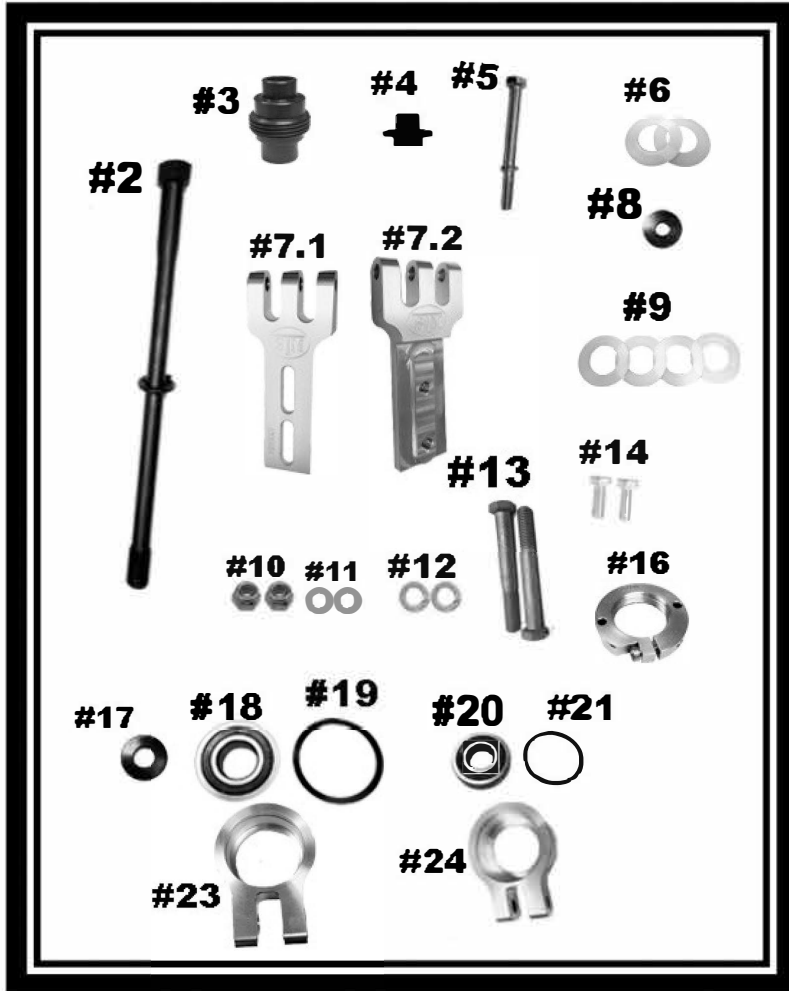

FOR DRAG RACING APPLICATIONS ONLY

STM Powersports
(248) 673-8408

www.stmpowersports.com

9/24/2021

Tied Clutch Brace - Screw-On, HD & Standard 30-33MM & Ski-Doo Primary
Part# 1001492

Item #	Quantity	Description	Part Number
2	1	Primary clutch bolt & lock washer	Per application
3	1	Screw On 30mm Adjuster Base	1001192
4	1	Secondary Bearing Post	Per application
5	1	Secondary Retaining Bolt & lock washer	Per application
6	2	.030 Shim	1001173
BRACKETS- Only 1 Size is Used			
		10.5" Center to Center	11.5" Center to Center
		12.5" Center to Center	
7.1-Lower		1001484	1001486
7.2 Upper		1001485	1001487
8	1	Secondary Retaining Washer for M10 Bolt	1001219
	or	For M8 bolt	1001217
9	4	.060 Shim	1001172
10	2	Flanged Nyloc Nut for Bracket Adjustment	3/8-16-NYLOCNUT
11	2	3/8" Flat Washer	3/8FW
12	2	3/8" Lock Washer	3/8LW
13	2	Bracket to Bearing Carrier Bolt	3/8-16x3
14	2	Bracket Length Adjustment Bolt	3/8-16x1" HHCS
16	1	Belt Spacing Adjuster Nut	1001171
17	1	Primary Bolt Retaining Washer	1001180
18	1	Primary Post Bearing	1001469
19	1	Primary Post Bearing Retaining Snap Ring	WHM-200
20	1	Secondary Post Bearing	1001470
21	1	Secondary Post Bearing Retaining Snap Ring	WHM-175
23	1	Primary Post Bearing Carrier	1001159
24	1	Secondary Post Bearing Carrier	1001160

DISCLAIMER:

This is an aftermarket performance product. It is the consumer's responsibility to read and follow the appropriate procedures listed for using this product. Consumer accepts all consequences by not following the above procedures. STM is not liable for any personal or property damage caused by this product.



IMPORTANT READ BEFORE INSTALLING WARNING:

The high-performance products you purchased are not for installation or operation by "Consumers", as defined by Magnuson-Moss Warranty Act. Do not install any performance parts or services unless you have the technical ability to properly set-up the entire machine to compensate for the installation of those parts. References in most of our literature to "bolt-on-parts" only indicate the parts are removable from the engine (as opposed to porting or machining type modifications). It is not meant to imply that the parts can be installed without additional modifications. The necessary work and expertise needed to install different products varies. Instructions, where provided, are given to assist in installation only; they are NOT a substitute for mechanical experience in setting up racing snowmobiles, watercraft or land based vehicles. References to performance gains, reliability, ease of installation, etc. are based on our, and outside customer's experiences. This is NOT a guarantee of similar performance in every installation. While we sell proven hardware, in the end it's up to the individual racer to make the most of that hardware in his/her application.

STM Powersports
(248) 673-8408

www.stmpowersports.com

9/24/2021