

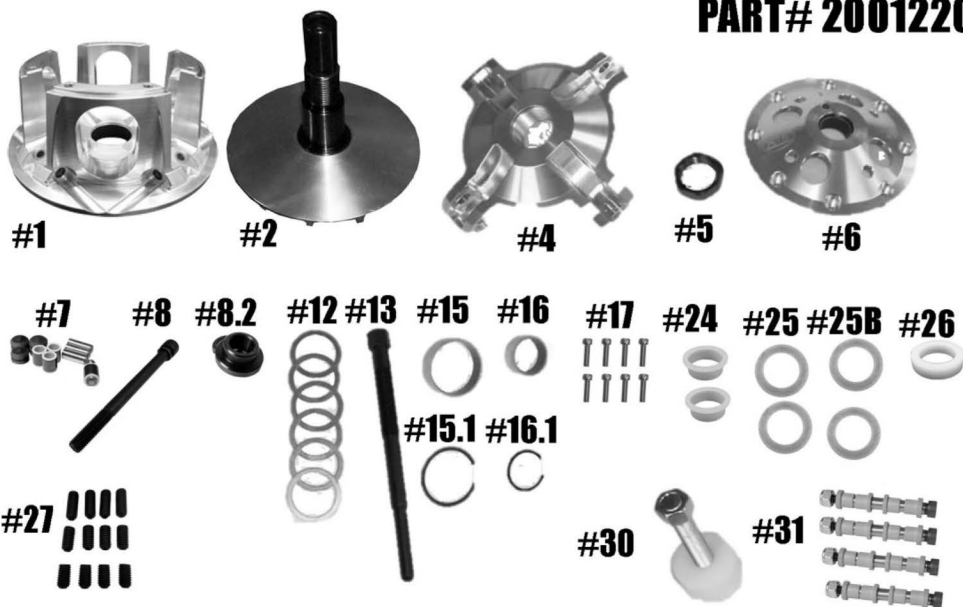

STM RAGE 4 XP-900 WIDE BELT CONVERSION_PRIMARY



PART# 2001220



QTY	ITEM#	DESCRIPTION	PART #
1	1	RAGE 4 MOVABLE SHEAVE	1001087
1	2	FIXED SHEAVE AND POST ASSY	2001107/2001083
1	4	SPIDER (Torque to 500 ft/lbs)	1001265
1	5	SPIDER NUT (Torque to 550 ft/lbs)	3001005
1	6	COVER	1001090
1	7	COMPOSITE BUSHING SPIDER PIN-ROLLER KIT	1001651
1	8	BOLT & LOCK WASHER - Torque to 60-75 ft/lbs.	1001261
1	8.2	CLUTCH BOLT SPACER	1001396
6	12	.03 BELT SHIM	1001403
1	13	PULLER	1001189
1	15	MOVABLE BUSHING	2610
1	15.1	MOVABLE RETAINING CLIP	VH181
1	16	COVER BUSHING	1810
1	16.1	COVER RETAINING CLIP	VH131
1	17	COVER SCREW SET	1001095
2	24	TRA SPRING BUSHING	1001091
2	25	.03 SPIDER SHIM	C154445
2	25B	.06 SPIDER SHIM	C154446
1	26	SPRING SPACER	1001092
1	27	SET SCREW SET	1001094
1	30	COMPRESSION TOOL (Sold Separately)	1001122
4	31	CONVERSION PIN OPTIONS	
		5/16" FIXED PIN .570 WIDE WEIGHT	1001319
		5/16" NON-FIXED PIN .570 WIDE WEIGHT	1001320
		5/16" FIXED PIN .470 WIDE WEIGHT	1001321
		5/16" NON-FIXED PIN .470 WIDE WEIGHT	1001322

***** Please visit website for item pricing *****

STM Powersports
(248) 673-8408

www.stmpowersports.com

1/25/2023